

FT12-50Ah 12V50Ah

Valve Regulated Lead Acid Battery



● Specifications

| | | |
|-----------------------|------------------------|---------------------|
| Nominal voltage | 12V (6 cells per unit) | |
| Rated capacity (10HR) | 50Ah/10.8V | |
| Dimensions | Length | 277±2mm (10.91inch) |
| | Width | 106±2mm (4.17inch) |
| | Height | 221±2mm (8.70inch) |
| | Total height | 221±2mm (8.70inch) |
| Approx. weight | 16.00kg (35.30lbs)±3% | |

● Outer dimensions (mm)

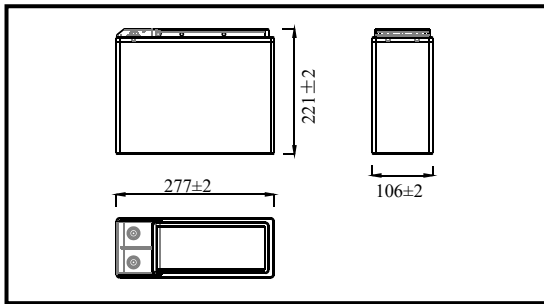

● Terminal type (mm)

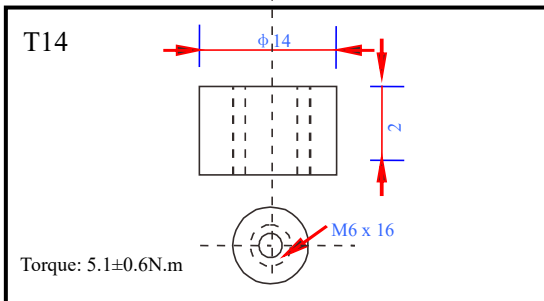

● Characteristics

| | | |
|---|---|--|
| Capacity (25°C) | 10HR (10.8V) | 50Ah |
| | 3HR (10.8V) | 37.5Ah |
| | 1HR (10.5V) | 27.5Ah |
| Terminal type | | T14 |
| Internal resistance (Fully charged, 25°C) | | Approx. 7.5mΩ |
| Capacity affected by temperature (10HR) | 40°C | 102% |
| | 25°C | 100% |
| | 0°C | 85% |
| | -15°C | 65% |
| Self-discharge (25°C) | 3 months | Remaining capacity: 91% |
| | 6 months | Remaining capacity: 82% |
| | 12 months | Remaining capacity: 65% |
| Nominal operating temperature | | 25°C±3°C (77°F±5°F) |
| Operating temperature range | Discharge | -15°C~50°C (5°F~122°F) |
| | Charge | -10°C~50°C (14°F~122°F) |
| | Storage | -20°C~50°C (-4°F~122°F) |
| Float charging voltage (25°C) | | 13.50 to 13.80V Temperature compensation: -18mV/°C/Block |
| Cyclic charging voltage (25°C) | | 14.50 to 15.00V Temperature compensation: -30mV/°C/Block |
| Maximum charging current | | 15A |
| Maximum discharge current | | 400A (5 sec.) |
| Design life | 12 years for floating (25°C) | |
| | Eurobat (20°C): 10-12 years, long life. | |

● Construction

| Component | Positive plate | Negative plate | Container | Cover | Separator | Electrolyte | Safety valve | Terminal |
|--------------|----------------|----------------|-----------|-------|-----------|---------------|--------------|----------|
| Raw material | Lead dioxide | Lead | ABS | ABS | AGM | Sulfuric acid | Rubber | Copper |

● Constant current discharge characteristics unit: Ampere/Block (at 25°C, 77°F)

| F.V/Time | 10min | 15min | 30min | 60min | 2h | 3h | 4h | 5h | 8h | 10h | 20h |
|----------|-------|-------|-------|-------|------|------|------|------|------|------|------|
| 9.60V | 107 | 82.3 | 49.2 | 30.3 | 18.3 | 13.2 | 10.5 | 8.98 | 6.17 | 5.09 | 2.70 |
| 9.90V | 104 | 80.3 | 48.3 | 29.8 | 18.2 | 13.1 | 10.4 | 8.92 | 6.13 | 5.08 | 2.69 |
| 10.2V | 99.3 | 77.4 | 46.8 | 29.1 | 18.0 | 13.0 | 10.4 | 8.86 | 6.09 | 5.07 | 2.68 |
| 10.5V | 95.1 | 74.7 | 45.7 | 28.2 | 17.7 | 12.9 | 10.3 | 8.80 | 6.05 | 5.04 | 2.67 |
| 10.8V | 89.7 | 70.8 | 44.0 | 27.3 | 17.3 | 12.5 | 10.0 | 8.54 | 5.87 | 5.00 | 2.65 |

● Constant power discharge characteristics unit: Watt/Block (at 25°C, 77°F)

| F.V/Time | 10min | 15min | 30min | 60min | 2h | 3h | 4h | 5h | 8h | 10h | 20h |
|----------|-------|-------|-------|-------|-----|-----|-----|-----|------|------|------|
| 9.60V | 1154 | 904 | 553 | 345 | 212 | 155 | 124 | 106 | 73.3 | 60.8 | 32.4 |
| 9.90V | 1119 | 882 | 541 | 340 | 210 | 154 | 123 | 105 | 72.9 | 60.7 | 32.2 |
| 10.2V | 1073 | 850 | 525 | 331 | 208 | 153 | 122 | 105 | 72.4 | 60.5 | 32.2 |
| 10.5V | 1027 | 821 | 512 | 321 | 205 | 152 | 121 | 104 | 71.9 | 60.1 | 30.0 |
| 10.8V | 969 | 777 | 493 | 311 | 200 | 147 | 117 | 101 | 69.7 | 59.7 | 31.8 |

Note 1: Above characteristics data can be obtained within three charge and discharge cycles.

● Discharge characteristics (25°C)

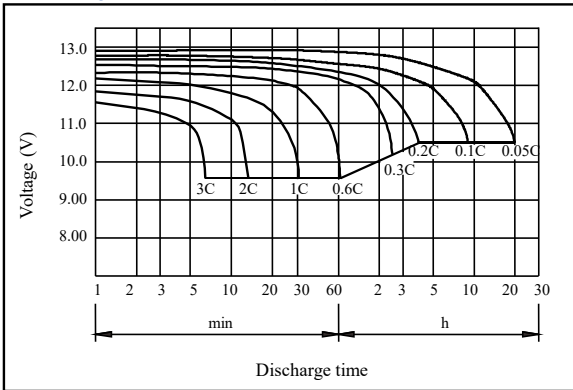

● Charging characteristics (25°C)

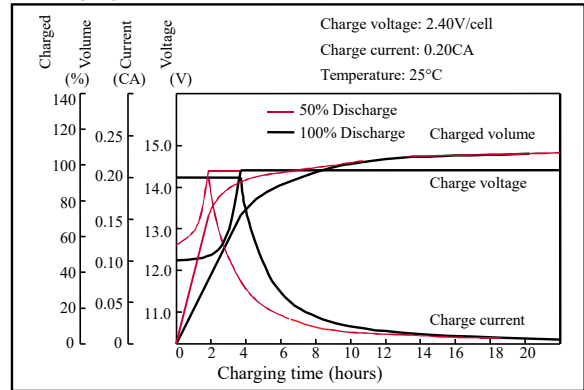

● Temperature effects on capacity

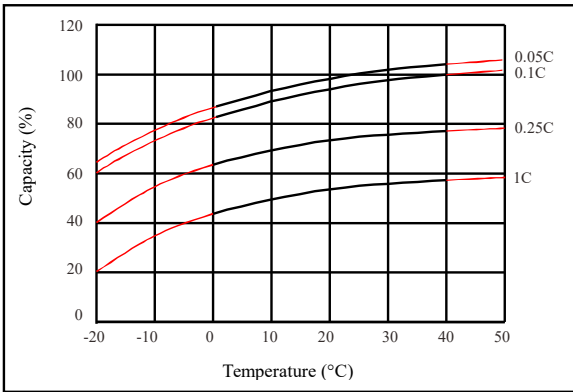

● Self-discharge characteristics

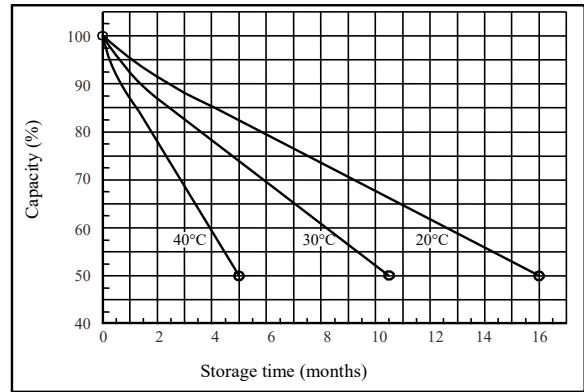

● Floating life on temperature

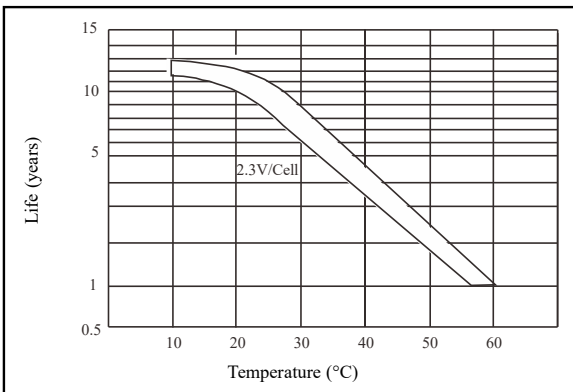

● Cycle life on D.O.D (25°C)

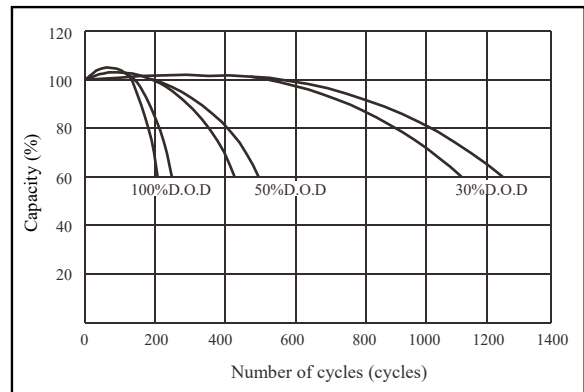

● Relationship for OCV and capacity (25°C)

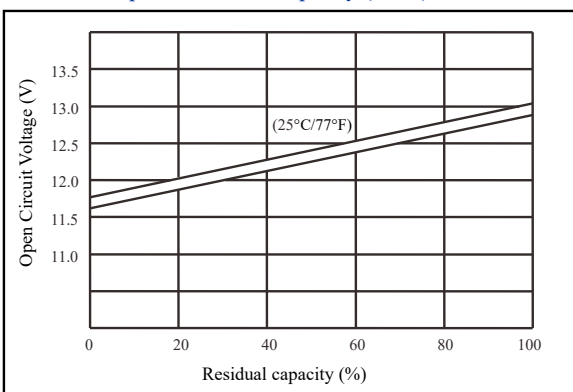

● Relationship for charging voltage and temperature

